

ID: 2016-ISFT-437

The Development Online Content Management System using Responsive Design Techniques for Organization on Mobile Device

Chanida Kaewphet¹, Anutita Lekpech², Woranuch Chan-o³

^{1,2,3}Faculty of Business Administration and Information Technology, Rajamangala University of Technology Suvarnabhumi., 450 Moo.6 Suphanburi - Chainat Street, Yanyao, Samchuk, Supahanburi, 72130, Thailand

¹froggy_piggy@hotmail.com

Abstract: The objective of this Development System were to 1) Study and System Analysis. Online Content Management Systems for Organization on Mobile Devices. 2) Develop and assess the efficiency of Online Content Management Systems for Organization on Mobile Devices. The Online Content Management Systems for Organization on Mobile Devices is the tool for website development. You can develop website by computer desktop, notebook, smartphone or tablet. The public can access website with variety of channel. The Content Management Systems for Organization on Mobile Devices is mainly constructed by PHP Language and uses database server program for storing Data. The development uses responsive web design technique and media query for developing website so the system can be used on mobile devices.

Keywords: Responsive design, Mobile device, CMS

1. INTRODUCTION

The portable device has become a part of everyday life precisely because it is used for several functions and easy to access to the Internet. The survey from www.hyperweb.ca has shown the number of the mobile Internet users has increased twice in 2012, and it is still increasing rapidly. Another survey from Thailand Internet User Profile said that 32% of Internet users in Thailand use their smart phone and tablet instead of desktop to access the Internet. It is increasing rapidly since 2001 and their number of usage hours per week is increasing 76.3%. The desktop is the most popular device for using the Internet, then laptop, smart phone, tablet, etc.

The survey of Internet Usage in Thailand 2014 from Electronic Transactions Development Agency said the average of Internet usage hours is increasing from 2013 to 50.4 hours per week or 7.2 hours per day. Smart phone is the most popular devices that use for accessing to the Internet. From the survey, the consumer uses a smart phone for access the Internet 77.1 %, and the usage hours are 6.6 hours per day which higher than the usage hours of desktop

and laptop 69.4 % and 49.5 %. The results let the many organizations to change the marketing and strategic plan related the consumer behavior. They have a promotion plan on the search engine or social media that have many people use it. The campaign helps them to reach many people who using the smart phone or tablet. The website development that supported the mobile devices is the significant key, and they need to hire an expert to develop the website. The budget needs to perform all devices may be high. So, the Content Management System is the one tool for organization to reach the people and help to create a website that performs all devices [1-4].

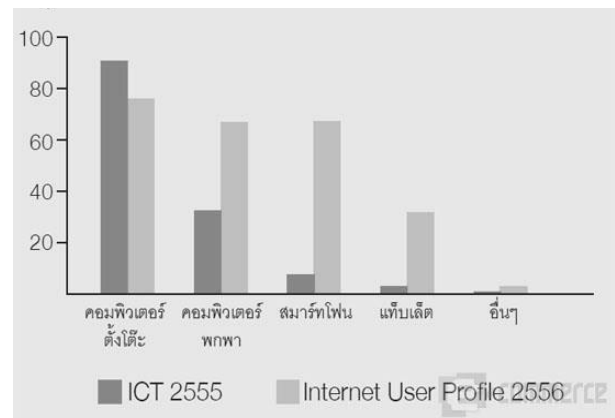

Fig. 1. Internet Usage by Device since 2012 – 2013

2. OBJECTIVES

- 2.1 To study and analysis the content management system for organization on the mobile devices.
- 2.2 To develop and benchmarks the content management system for organization on the mobile devices.

3. MATERIALS AND METHODS

The procedures to develop the content management system on a portable device are as follows:

3.1 BACKGROUND

- 1) Study the Content Management System (CMS) in order to develop the system to help the organization manage the website without technical knowledge.
- 2) Study the web-based and database technology from an existing system of other organizations. It should have implemented as web-based system and let them manage on a web-browser.
- 3) Study the Server-Client approach in order to serve online service.
- 4) Study the System Analysis techniques and System Development Life Cycle (SDLC) in order to develop the system follow the business requirements.
- 5) Study the Responsive Web Design technique in order to display on any size of a screen of any devices such as display full features on a desktop screen while display on the smart phone or tables should display the menu fit on the current resolution. This technique let user ease to access the website with the same URL. It is no need to redirect to the separate mobile compatible website. Another advantage, it helps the organization's website to perform a good Search Engine Optimization (SEO) because it uses the same contents and URL. It is easy to manage only single website.
- 6) Study the HTML5 and CSS3 technology; these technologies help the system perform the Responsive Web Design perfectly.

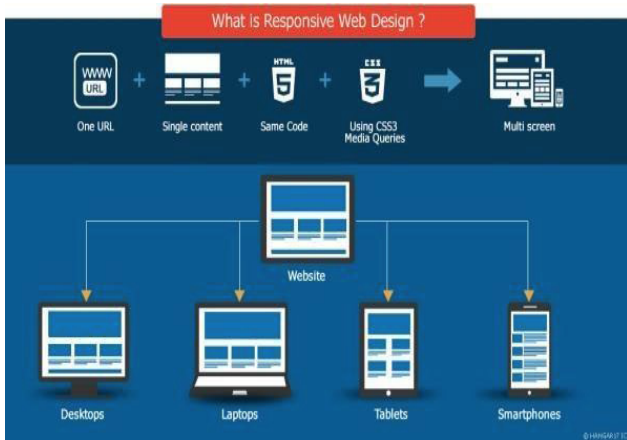

Fig. 2. Responsive Web Design Technique

3.2 ANALYSIS AND DESIGN WITH DATA FLOW DIAGRAM (DFD) AND ENTITY-RELATIONSHIP (ERD)

- 1) Analysis from the business requirements, then classified into three main agents who use the system, which are administrators, members, and general users.

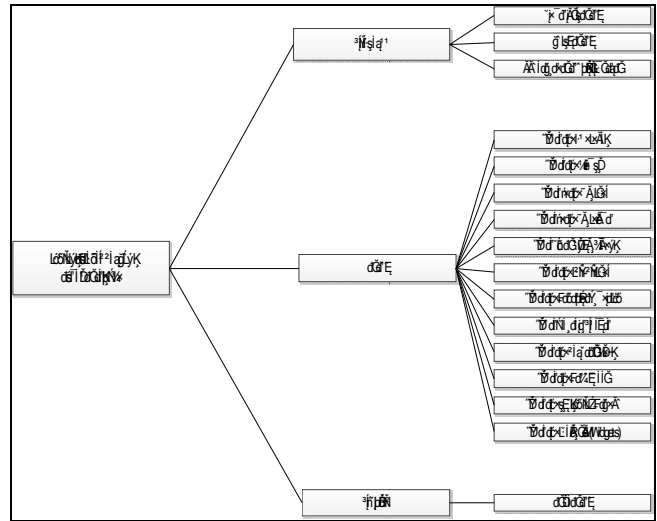

Fig. 3. System structure with Three Agents

2) System Design with Data Flow Diagram (DFD)

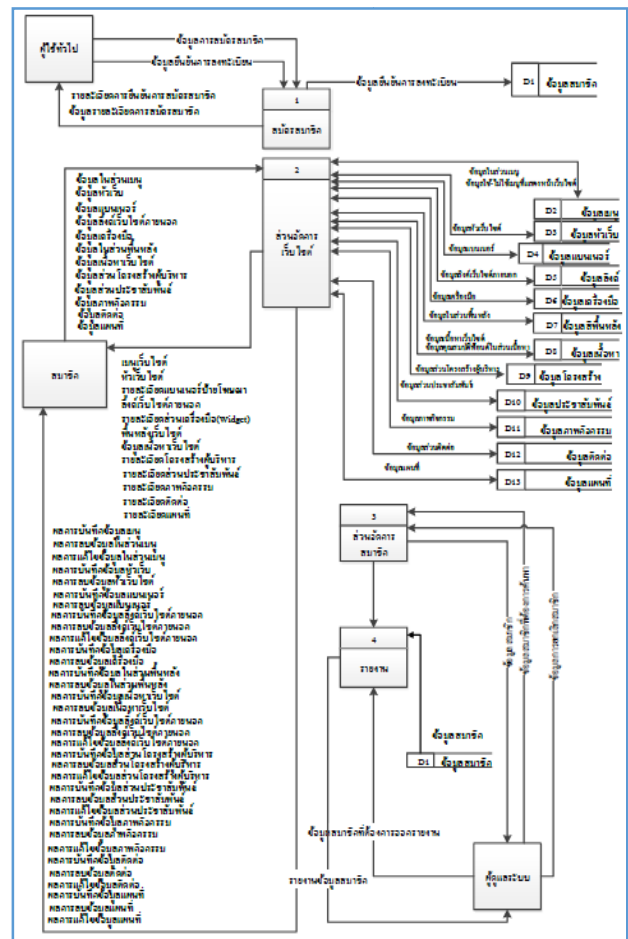

Fig. 4. Data Flow Diagram (DFD)

- 3) System Design with Entity-relationship Diagram (ERD)

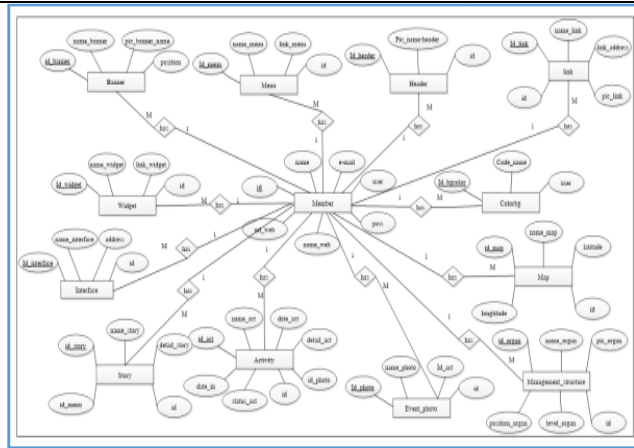

Fig. 5. Entity-relationship Diagram (ERD)

Responsive Web Design

A Responsive web design was used on a website to allow users to view the website on any device.

1) Homepage



Fig. 6. Homepage on Desktop Screen



Fig. 7. Homepage on Smartphone and Tablet Screen

2) Administration Page



Fig.8. Administration page on Desktop Screen

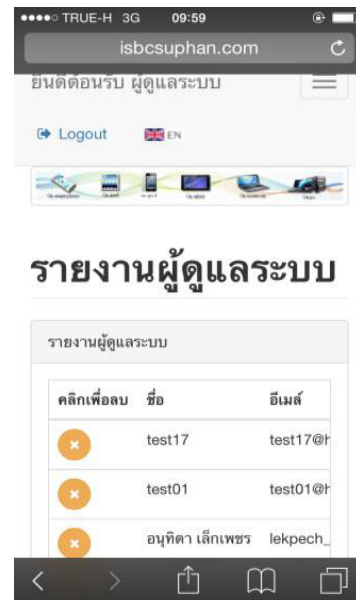

Fig.9. Administration Page on Smartphone and Tablet Screen

3) Membership Page

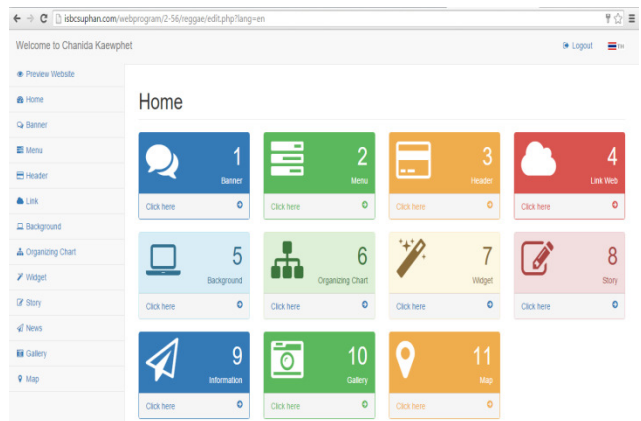
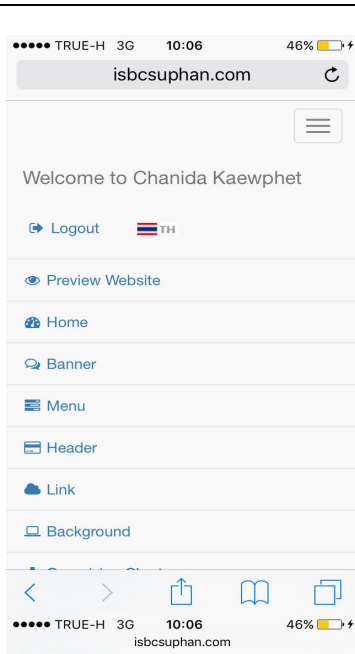

Fig. 10. Membership page on Desktop Screen



Home

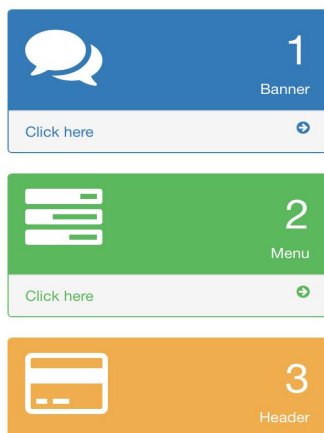

Fig. 11. Membership page on Smartphone and Tablet Screen

4) General User's Page



Fig. 12. Registration page for General User on Desktop Screen



Fig.13. Registration page for General User on Smartphone and Tablet Screen

3.3 DEVELOPMENT

Using PHP and MySQL develop the system. The functional requirements are as follows:

- 1) Website
 - Organization Information
 - General Information
 - Organizational Structure
 - News
 - Events and Activities
 - Maps
 - Website Links
 - Contact
- 2) Administration
 - Administrator must be able to login for searching the user information.
 - Administrator must be able to deactivate the user's account.
- 3) Member
 - Member must be able to add and delete the left and right banner on website.
 - Member must be able to add and delete the background.
 - Member must be able to add and delete the left and top menu.
 - Member must be able to add, delete, and update the content on a Website.

- Member must be able to change font property in content.
- Member must be able to change font.
- Member must be able to change font color.
- Member must be able to change font size.
- Member must be able to choose to show and hide the menu items on Website.
- Member must be able to choose the language preference (Thai/English) on Website.
- Member must be able to add, delete, and update the 'Organization Structure' web page.
- Member must be able to add, delete, and update the 'News' web page.
- Member must be able to add, delete, and update the 'Events and Activities' web page.
- Member must be able to add, delete, and update the 'Websites Links' web page.
- Member must be able to add and delete Website header.
- Member must be able to add and delete the widgets on the right-hand side of the website.
- Member must be able to add the calendar widget.
- Member must be able to add the oil price widget.
- Member must be able to add the weather forecast widget.

4) General User

- General user must be able to register.

5) Evaluation

- There are two steps for evaluating the system, which are evaluation by developer and evaluation by expert users.
- There are two techniques to evaluate the system by developers, which are White Box Technique and Black Box Technique.
- White Box Technique focused on the mechanism inside the system, when found any errors try to fix until the system work properly.
- Black Box Technique focused on output from a system. This technique will perform the sample data input to the system and ignore any mechanism inside the system.
- Evaluation by expert users, five expert users will evaluate the performance of algorithms of the system and the steps following as:
- The steps of evaluation creation, it implies on four categories, which are Function Requirement Test,

Functional Test, Usability Test, and Security. The question for adjusting and changing issues that related to a system was selected to expert users. The questions help to adjust and change the system to work correctly and follow the business requirements.

- Indicator of this evaluation uses the qualitative rating scales with five levels and quantitative rating scale with five levels.

6) Maintenance

- This phase aims to change to the system perform correctly and properly after testing the system. When the system has no malfunction such as system working issue, the connection between modules' issue, and performance issue, etc. it needs to perform a checking and changing the code of the system before create the manual.

4. RESULTS

There are two groups of user, expert users and general users. 1) general user group 30 person from organization 2) expert users 5 person. Both will evaluate the website on mobile devices. Next, they will evaluate other four websites, which performed the same technique. The evaluated results, which compare with other websites, which performed the content management system for mobile devices are shown below.

A. Evaluation Results from Expert users and General users

- 1) The evaluation of content management system for mobile device that is running on the desktop environment from expert users at 'Good' level presented the score 4.19.
- 2) The evaluation of content management system for mobile device that is running on the smartphone environment from expert users at 'Good' level presented the score 4.22.
- 3) The evaluation of content management system for mobile device that is running on the tablet environment from expert users at 'Good' level presented the score 4.27.
- 4) The evaluation of content management system for mobile device that is running on the desktop environment from general users at 'Best' level presented the score 4.51.
- 5) The evaluation of content management system for mobile device that is running on the smartphone environment from general users at 'Good' level presented the score 4.45.
- 6) The evaluation of content management system for mobile device that is running on the tablet environment from general users at 'Good' level presented the score 4.40.

B) Comparisons with Other websites

TABLE 1: Comparisons with Other Websites that Performed Same Technique

Functional/ Modules	Websites				
	Developed Website	A	B	C	D
1. Supported a Responsive Web Design	X			X	
2. Maps	X		X		
3. Language Preference	X	X			
4. Website Header Customization	X	X	X	X	X
5. Organizational Structure	X	X	X		
6. News	X	X	X	X	X
7. Event Gallery	X	X	X	X	X
8. Hide/Show Menu	X		X	X	
9. External Links	X	X	X	X	
10. Templates			X		X
11. Webboard					X
12. Banner	X				X
13. Membership					X

5. CONCLUSIONS

The Development System Online Content Management using Responsive Design Techniques for Organization on Mobile Device was work correctly on desktop, smart phone device, and tablet. However, the limitation of cascade style sheet file, which performed the responsive technique in templates, not work correctly on Android devices.

ACKNOWLEDGEMENT

The authors would like to acknowledge discovery grant for funding this research.

REFERENCES

- [1] Curcic, Open source distance learning solution for government.
<http://unpan1.un.org/intradoc/groups/public/documents/other/unpan022060.pdf#s>

earch=%22open%20source%20mambo%20case%20study%22 (Accessed on March 14, 2014)

- [2] Electronic Transactions Development Agency (Public Organization), <https://www.eta.or.th> (Accessed on April 8, 2014)
- [3] Mikic, R.; Anido, L. M-learning Standardization: Concepts and New Ideas about Learner Profile. In International Federation for Information Processing, Volume 210, Education of the 21' Century-Impact of ICT and Digital Resources. Eds. D. Kumar, and Turner X, Boston: Springer, 2006, pp. 375-379
- [4] Charuchaoenchai, T. Design and implementation of a content management system with collaboration feature: a case study at ThaiRoHS.org. Thesis Doctoral Degree, Information Technology (International Program), King Mongkut's University of Technology North Bangkok, 2006